

For More Info



Click Here ---->

SEM Model 7050P Paper Shredder



Please read this manual carefully. It will answer all your questions regarding installation, operation and trouble-shooting.

IMPORTANT:

Be sure to adhere to all safety suggestions listed

**Order on-line GSA Customers www.fedshred.com
Commercial Customers www.semshred.com**

THE WORLD LEADER IN DOCUMENT AND SENSITIVE WASTE DESTRUCTION SOLUTIONS

SHREDDERS • DISINTEGRATORS • SECURITY WASTE CONTAINERS • DEGAUSSERS



5 Walkup Drive • Westboro, MA 01581

TABLE OF CONTENTS

READ CAREFULLY BEFORE USING

These Paper Shredders are designed for the in-office destruction of paper documents to an unidentified waste. Proper care and use of your shredder will insure many years of trouble free operation.

For More Info

Click Here --->



Content	Page
General	3
Safety Instructions & Application	3
Installation	3-4
Transportation	4
Pre-assembly	5
Power Supply .	5
Checking Rotating Direction	5
Operating	5-7
Troubleshooting	7-8
Accessories .	8
Technical Data	8
Recommended Spare Parts	8
Using and Ordering Spare Parts	9
Customer Service	9

For More Info 
Click Here ---->

IMPORTANT SAFETY PROCEDURES

Your new paper shredder incorporates powerful, heavy duty cutting mechanisms.

Serious and permanent injury may result if proper precautions are not followed.



1. This equipment should never be operated by children or individuals untrained in or incapable of understanding the safety precautions!



2. Do not reach into the feed opening for any reason! Never insert fingers, hands, other extremities or objects not meant to be shredded into the feed openings!

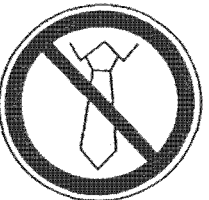

3. Do not operate or come in close proximity to this equipment wearing long hair, necktie, loose clothing or jewelry, which may activate a photoelectric on/off switch and/or be pulled into the machine!

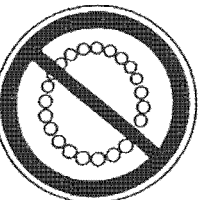

4. Maintenance or repair of this equipment should be performed only by trained, authorized service personnel.

5. Always disconnect electric power (unplug) before removing or opening the cover or other panel giving access to internal mechanisms.

GENERAL

This instruction manual helps you learn the safe and comfortable operation with this machine. Before working with the machine please read these instructions carefully and consider the safety regulations.

SAFETY INSTRUCTIONS

DANGER! Non-compliance with the instructions may endanger persons.

WARNING! Non-compliance with the instructions may cause damage to the machine.

The operating instructions must always be available for the operator.

For More Info



Click Here --->

APPLICATION

The machine is capable of shredding loose and crumpled paper as well as cartons with staples. Due to material separation we recommend to avoid shredding plastic foils at the same time.

DANGER!

Only Qualified persons are allowed to operate the machine

No operation by children

DANGER!

Do not shred any strapping materials or fluids which can loop, splinter, chemically react or explode.

WARNING!

Feeding large steel components, rigid materials, screws or nails will damage the shredding mechanism.

INSTALLATION

The machine is mounted on castors and easy to move. The machine must be installed on a firm, level, dry floor.

DANGER!

- The machine must not be used outside.
- Do not use in the vicinity of flammable liquids or gases.
- Do not use in wet environments.
- Protect the power cable from extreme heat, oil, and sharp edges.

WARNING!

- Do not cover the ventilation slits. Follow the space assignment plan carefully.
- Consider the floor Loading. Weight approximately 2630lbs (1200kg).

Space Assignment Plan

For More Info



Click Here --->

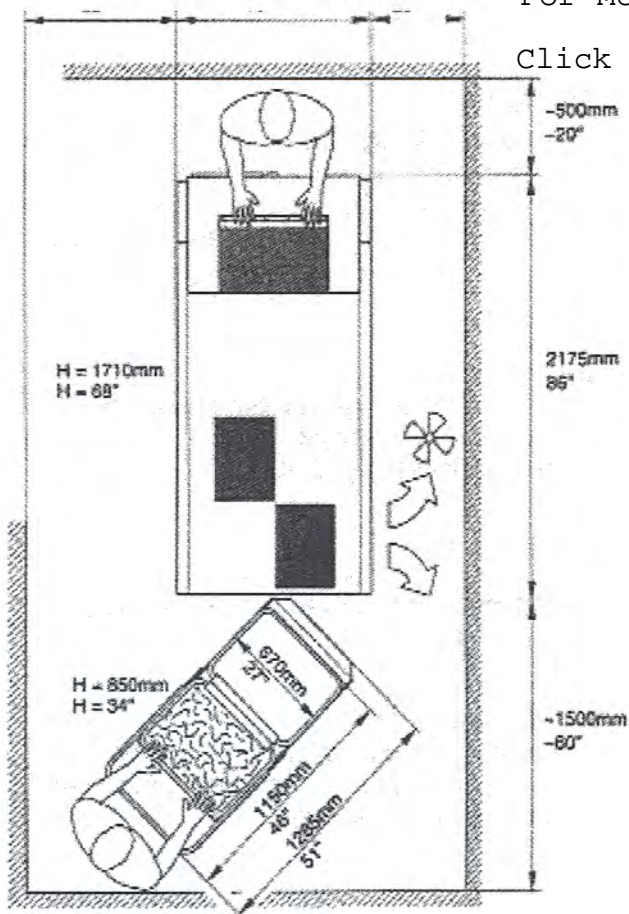

TRANSPORTATION

ATTENTION! Do not raise the machine higher than necessary to avoid tipping.

Transport is only possible from the back and with built-in transport safety device (4) and (5).

Make sure the lifting truck is centered under the machine.

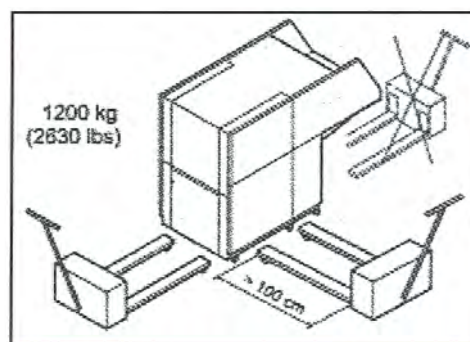
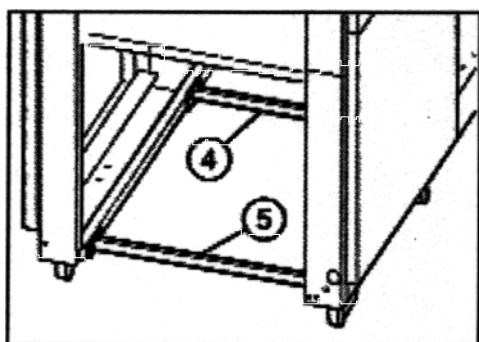

PRE-ASSEMBLY

- Open the door
- Remove the transport safety device (4) and (5) and keep for later transport use
- Mount the supporting screws (6)
- Screw down the supporting screws until the rear rolls are relieved.

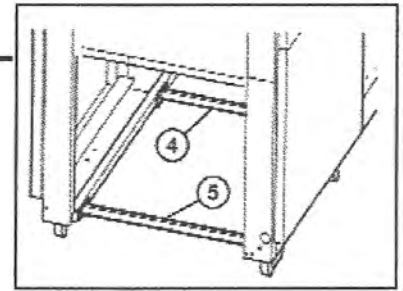

Mount the waste bin

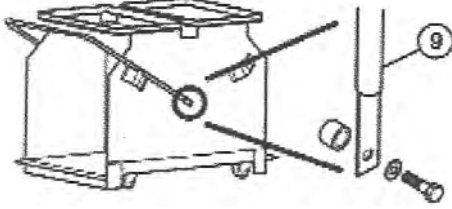

- Mount the shackle (9)
- Change both plastic bag (as described under changing the waste bag)
- Push the waste bin into the machine
- Close the door

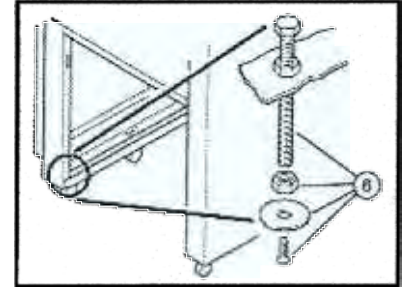

POWER SUPPLY FOR 208V OR 220V=70AMPS MINIMUM SERVICE

The name plate is located at the rear of the machine.

- Data stated on the rating plate must correspond to the values of the power supply unit.
- Voltage "V" • Frequency "Hz" • Power Consumption "A"

Connect the supplied power cord, using a ground.

CHECKING ROTATING DIRECTION

Operate the machine for a short time as described under "Operation"

- The material is transported into the machine by the conveyor belt.

When the machine works in the opposite direction

As the machine is wired according to the IEC standardized rotary field, when changing the rotary direction we recommend that this is performed by an experienced specialist. The rotary direction may be changed by exchanging the "L1" and "L2" connections in the plug.

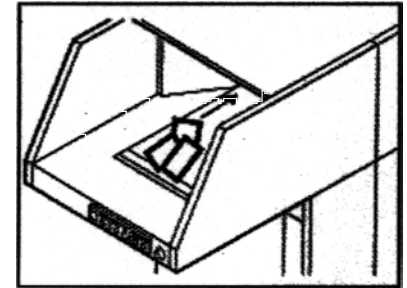

DANGER! Incorrect exchange of the connections may endanger the operator. In doubt, this work should be performed by an electrical specialist.

For More Info



Click Here ---->

OPERATING

The machine will only run when door is closed!

DANGER! The machine may only be operated by persons who have read and understood the operating instructions.

DANGER! Keep hands away from running shredding mechanism! The shredding mechanism may cause serious injury!

OPERATING ELEMENTS

- (1) Start
- (2) Stop and pilot light for door open
- (3) Reverse and the lamp waste bin full
- (4) Key Switch
- (5) Standby
- (6) Main switch (can also be used as emergency off button)
- (7) Pilot light temperature indicator
- (8) Emergency off

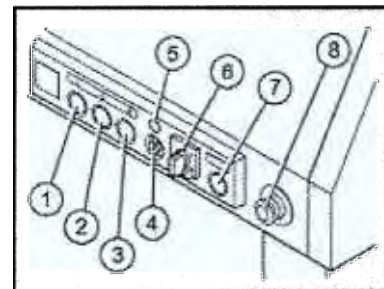

STARTING THE MACHINE

Do not shred any material which may loop or splinter. Material, which does not go through the cutting head can only be pushed in with the pusher (9). In case of danger, press emergency off button (8).

- Turn main switch (6) into position "I"
- Emergency button (8) must be unlocked (turn to the right)
- Turn on the key switch (4) turn to the right then the standby (5) illuminates
- Press and release the black button (1) Conveyor belt is running
- Feed the paper over the total width of the conveyor belt

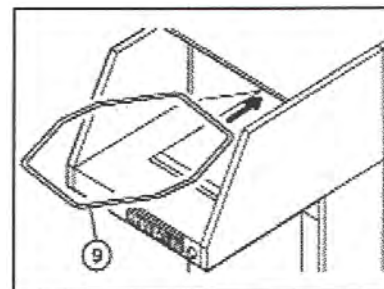

In case the quantity of material inserted is increased the machine automatically changes to a more powerful and slower function. If this performance is still not sufficient the machine starts to reverse shortly and afterwards runs again forward. The machine switches between both speed levels until all the material inserted is fully destroyed.

ATTENTION! If possible let the machine work at its normal speed. Shred continuous paper only in stacks

Stopping the Machine

- Press the red key (2) or press the emergency OFF button (8).

Keep hands away from running shredding mechanism!

- Yellow pilot light (7) appears
Temperature of the motor is too high
Decrease the material on the conveyor belt to make the machine work in normal speed
- Yellow pilot light (7) lights up
temperature is too high wait approximately 10 to 20 minutes until motor cools down.

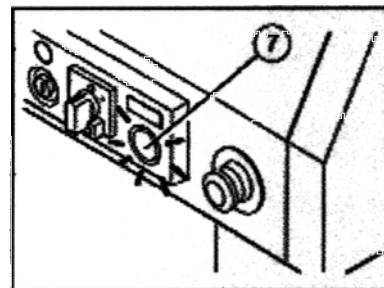

STOPPING THE MACHINE

For short breaks

- Press and release the red button (2) Conveyor belt stops

For longer breaks

- Turn main switch (6) to position "O" — the entire machine shuts down.
- Turn the key switch (4) and remove the key — now the machine is secured from unauthorized use.

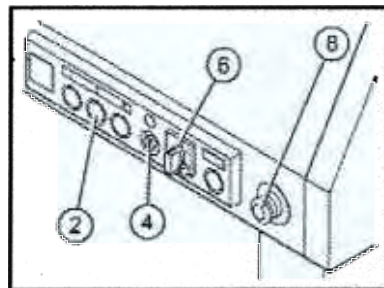

CHANGING THE WASTE BAG

If the lamp waste bag full lights up you should empty the waste bag.

- Open the door (9)
- Pull out the waste bin from the machine

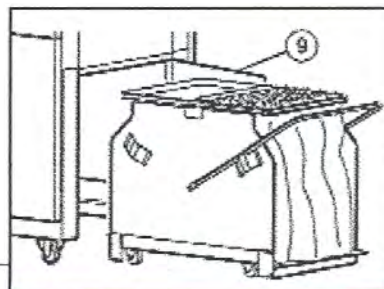

For More Info



Click Here --->

If one of both bags is full

- Turn the handle (10) to empty waste bag
- Turn the waste bin and push it into the machine with the full plastic bag in front
- Close the door (9)

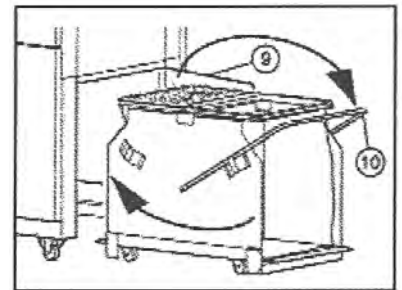

If both bags are full

- Remove the metal cover (11)
- Remove the round belt from the waste bag frame (12)
- Remove waste bags for storage on a pallet.
- Tie the bags (for sealing parts and binding wires see accessories)
- Place a new bag into the bag frame and fold it down approx. 12" to 15" to the outside. Tighten the bag with the plastic band
- Fasten the bag with the round belt
- Attach the metal cover (11)
- Close the door
- Check the function of the door switch. Start the machine. If the door is open the machine has to stop immediately

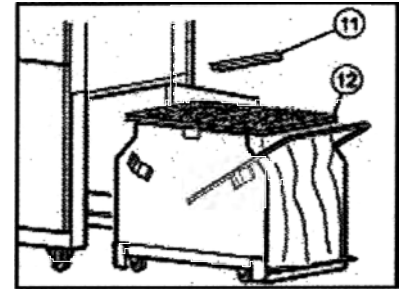

NOTE: Waste collection bags SEM part number 6425B190 50/Box

OILING THE SHREDDING MECHANISM

If the sheet capacity reduces or after bag is full we recommend that you oil the shredding mechanism

- Move the lever (13) of the oil pump once
- After this lubrication please let the machine run several times backwards and forwards alternately
- If the tank (14) is empty refill oil.
Type of oil: SEM Shred Oil #647OIL (4 Gallon case)

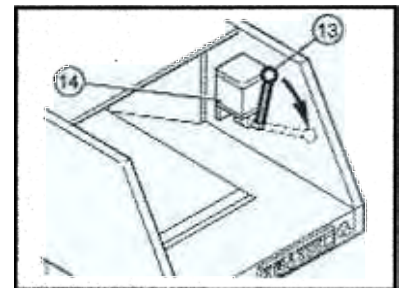
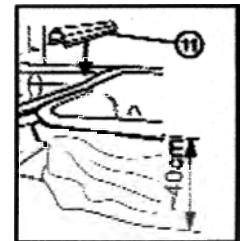
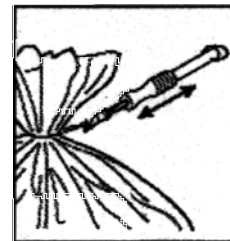

TROUBLESHOOTING

DANGER! Disconnect from the mains before starting any service work or before removing the cover.

MALFUNCTION: Standby (5) is not lighting up

- CAUSE:**
- The door is open
 - Main switch is OFF
 - The Emergency button is pressed
 - Key switch is not plugged in
 - On-site fuse

Machine is overloaded-the motor protection switch is re-activated after 10 minutes

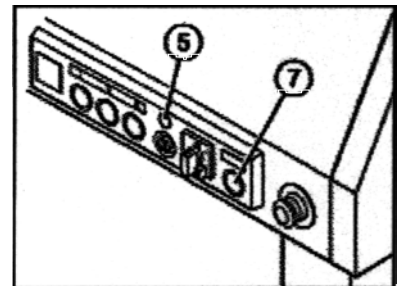

MALFUNCTION: Motor makes a buzzing noise and the machine shows no performance

CAUSE: One phase is missing

REMEDY: Check if all three phases are supplied with electric power (voltage) by an electrician

For More Info



Click Here --->

MALFUNCTION: Machine door is difficult to open

CAUSE: Guiding bar of the lower cutting head cover is dirty

REMEDY: Clean and grease the guiding bar

MALFUNCTION: Machine switches off during normal operation

CAUSE: Bag full control light will light — Shred bag is full

REMEDY: Change waste bag

For More Info

OR

Click Here --->



CAUSE: Yellow pilot light (7) lights up, temperature of the motor is too high

REMEDY: Wait approximately 10 to 20 minutes until machine cools down

ACCESSORIES

Plastic bags 350l (50 pieces) 9000 413

Pusher 9000 593

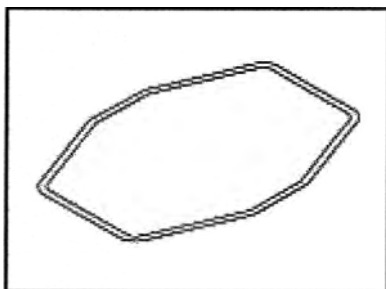

For closing the plastic bags:

Locking device 9000 591

Binding Wire (1000 pieces) 9000 597

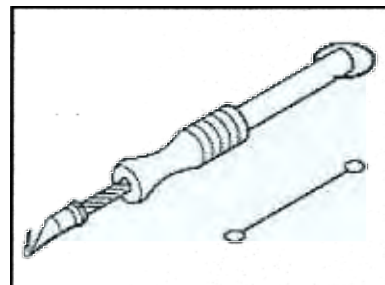

IMPORTANT: Only use manufacturer recommended accessories

TECHNICAL DATA

7050P

Shred Capacity: up to 500 Sheets
Shred Size: 5/16" x 3-1/8"
Speed: 45 FPM
Horsepower: 12-3/4HP (Dual drive 2 speed)
Dimensions: 67-1/2"H x 40-3/4"W x 85-1/2"D
Weight: 2500 lbs.
Power: 208V/230V 3 phase

RECOMMENDED SPARE PARTS

Replacement Plastic Waste Bags #190 Part Number 6425B190 50/Box

Shredder Lubricating Oil 4 gallon case Part Number 647OIL

USING AND ORDERING SPARE PARTS

- Only use original SEM spare part replacements
- We guarantee their quality and functional reliability
- Warranty claims on parts and/or service must be approved by SEM's Customer Service Manager

For More Info



Click Here ---->

HINTS FOR ORDERING SPARE PARTS

The spare parts shown on the following pages have part numbers. This spare parts list shows the following information with respect to the spare parts to be ordered.

- Part No.
- Designation
- Dimensions
- Item No.
- Quantity

In order to avoid errors and the delivery of wrong parts, each parts order should contain the following information.

- Machine No. (See nameplate)
- Part No. and designation of desired spare parts
- Quantity of desired spare parts
- Desired mode of shipment (e.g. post, freight, express)
- Full billing & shipping addresses, including contact person & telephone
- Machine Type

OPTIONAL ITEMS AVAILABLE

Replacement Plastic Waste Bags Part No. 639SB140
Shredder Lubricating Oil, Case of 8 pints, Part No. 649OIL8
Shredder Lubricating Oil, Case of 16 pints, Part No. 649OIL16

CUSTOMER SERVICE

To order spare parts or optional items you may contact the Authorized Service Rep. for your area, or SEM's Customer Service Dept. directly at the following address:

Security Engineered Machinery
P. O. Box 1045
Westboro, MA 01581

Tel: 800-225-9293

Fax: 508-366-6814

Website: Commercial www.semshred.com

Government www.fedshred.com

Email: info@semshred.com

ADDITIONAL SEM PRODUCTS



Automatic Oiler

For More Info

Click Here --->



Disintegrators/Industrial Shredders



Magnetic Media Degaussers



Recycling Collection Containers and Specialty Waste Receptacles

For detailed products information including all application and specifications contact

Customer Service at 1-800-225-9293

or via the web

Government www.fedshred.com or

Commercial www.semshred.com

THE WORLD LEADER IN DOCUMENT AND SENSITIVE WASTE DESTRUCTION SOLUTIONS

SHREDDERS • DISINTEGRATORS • SECURITY WASTE CONTAINERS • DEGAUSSERS



5 Walkup Drive • Westboro, MA 01581