

OPERATION MANUAL

for

Tabletop Paper Collator

FC-10

- Connected Use -

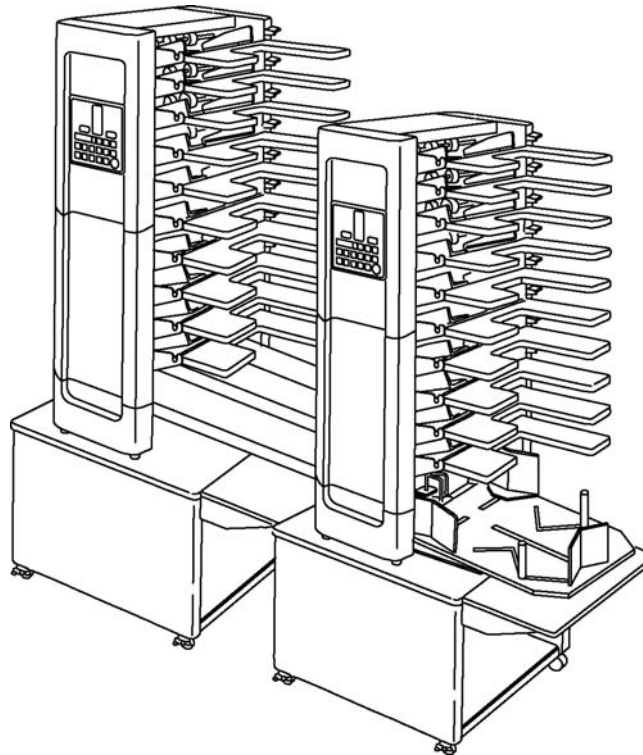

A PRODUCT OF



CORPORATION

The Leader in Paper Handling Equipment

1-800-223-2508

www.mbmcorp.com

APRIL.25.2005

For More Info  **mono**
Click Here ---> **Machines**

Safety Instructions

Definition of Symbols and Notes

In this manual following names and signs stand for possible dangers.

	<p>Danger This Symbol stands for immediate danger threatening the life and health of persons. Disregarding these instructions may cause severe damage to health and even serious injuries.</p>
	<p>Caution This symbol stands for an endangering situation that may occur. Disregarding these instructions may lead to slight injuries or damage to property.</p>
	<p>Note This symbol stands for notes, operational hints and other useful information. They are convenient for exploiting the machine's functional abilities.</p>

Danger	
	Operate the collator with designated AC current only. Use an exclusive outlet, as overloading may cause fire or an electrical shock.
	Do not plug or unplug the power cord from an outlet with a wet hand; it can result in an electrical shock.

Caution	
	Do not install the machine in a humid or dusty place; excessive humidity and dust can cause fire or physical injury.
	Never unplug the power cord from the outlet by gripping the cord itself. Doing so may damage the cord, causing fire or injury. Always disconnect the machine by gripping the plug.
	Be sure to remove the power plug from the outlet when moving the machine, otherwise it may damage the cord, causing fire or an injury.
	When the collator will not be used for several days, such during consecutive holidays, etc., be sure to unplug the power cord from the outlet for safety's sake.
	Do not place receptacles containing water, such as vases, flowerpots and cups, on the machine. Spilled water can cause fire or an electrical shock.
	Do not damage, destroy or process the power plug and cord. Placing heavy things on the cord, pulling it, or bending it forcibly may damage the plug and cord and cause fire or an electrical shock.
	Do not remove the cover of the machine, as it can cause an electrical shock or injury.
	Do not dismantle the machine, it may cause fire or an electrical shock.
	Continuing operation in spite of irregularities, such as overheating, smoking and unusual odor, may cause fire or an electrical shock. In such cases, turn off the power switch, remove the plug from the outlet and contact your dealer.
	When foreign substances, such as metal fragments, water or other liquids, fall into the machine, turn off the power switch immediately, remove the plug from the outlet and contact your dealer. Continued operation with such substances in the machine may cause fire or an electrical shock.

INTRODUCTION

Read this “Operation Manual” carefully before use.
Keep it at a specific place for handy reference.

Since the specifications of this machine are subject to change, be sure not to mistake this manual for one of a different model, descriptions of may differ.

CONTENTS

1. PRECAUTIONS FOR INSTALLATION AND USE	4
1.1 Place for installation	4
1.2 Confirmation of contents and attachments	4
2. COMPONENT NAME	4
3. HOW TO CONNECT TWO TABLETOP COLLATORS	5
4. HOW TO CONNECT THE CONNECTOR	8
5. HOW TO OPERATE TWO COLLATORS WHEN THEY ARE CONNECTED	9
6. RELOCATION OR DISPOSAL	10
6.1 Relocation	10
6.1.1 Removal of the machine from its present location	10
6.1.2 Transport	10
6.1.3 Installation	10
6.2 Disposal	10

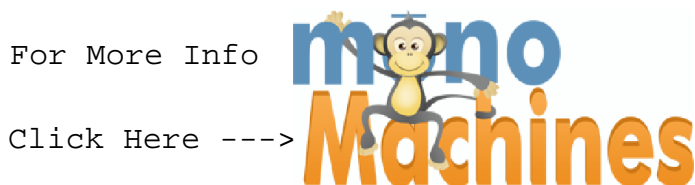

1. PRECAUTIONS FOR INSTALLATION AND USE

1.1 Place for installation

- Locations with extremely high or low temperatures. Room temperature should be between 5 and 35 degrees centigrade.
- Locations with the potential for producing electrical leaks, for example, owing to splashing water.
- Near heat sources
- Places exposed to wind
- Narrow spots with poor ventilation, or dark places
- Locations exposed to direct sunlight or other powerful light sources. Direct sunlight or other strong light sources may cause the optical sensor to malfunction. Install the machine in an appropriate place or shield the light with a heavy curtain or other material.

1.2 Confirmation of contents and attachments

After unpacking the collator, check the attachments. Should any part be missing, contact your dealer immediately.

- (1) Upper chassis fitting knob (2) Upper chassis (3) RKWS 4×6 screws (10 pcs)
(4) Fitting plate (L) (5) Bridge side plate (6) Connecting chassis (7) Two collators connecting cord

2. COMPONENT NAME

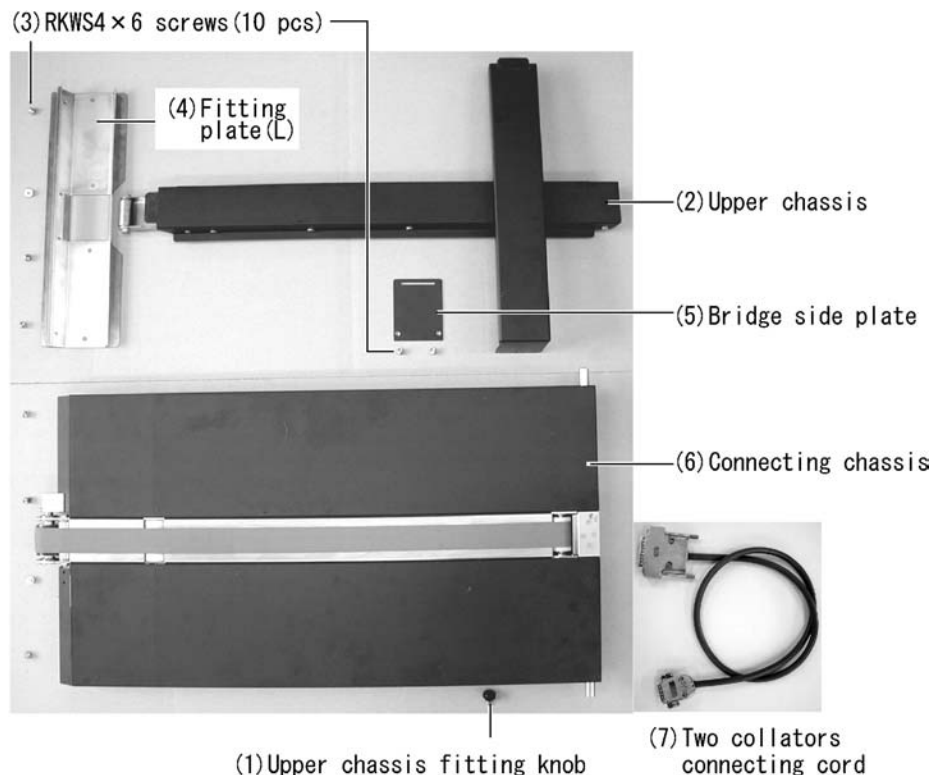

3. HOW TO CONNECT TWO TABLETOP COLLATORS

1. Assemble tabletop collator tables and install the right and left towers on them.

Caution!

- As for assembly of collator, refer to the assembly plan.
- In case two connected collators are used, be sure to install them on the collator tables designed for collator.
If two collators are not kept in parallel, it may cause paper feed trouble
- Fix the collator to the collator table firmly with metal fittings.

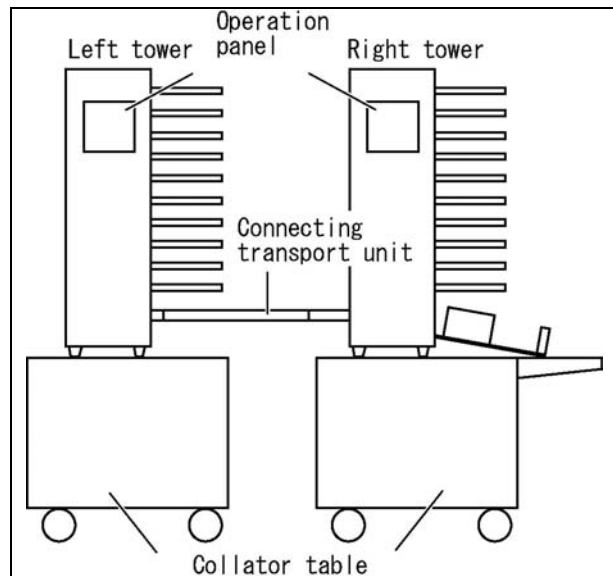

2. Switch the switching plate to "Connection" side.

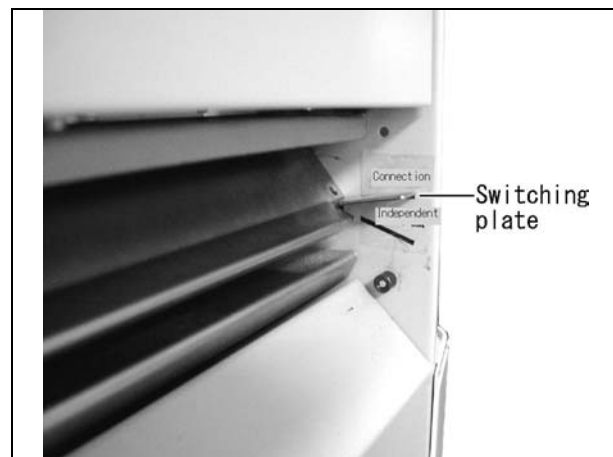

3. Using Phillips screwdriver, fit the L fitting plate to the wing beneath paper ejection of the left tower using RKWS4x6 screws (4 pcs) (4 locations).

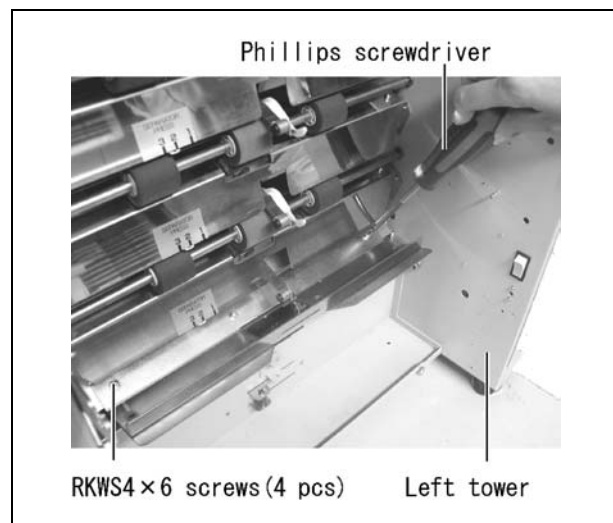

For More Info  Click Here --->

4. Fix the connecting chassis to the left tower

(1) It depends by the hand so that the ditch of operation driver in a left tower may become the same as the direction of the pin of connecting shaft, it matches, and the pin is set in the ditch.

Note!

Place a base or the like beneath the connecting chassis to keep the chassis level. It will make the assembly easier.

Caution!

If the parts are not fitted properly, the collators may not start to work, or it may cause machine trouble.

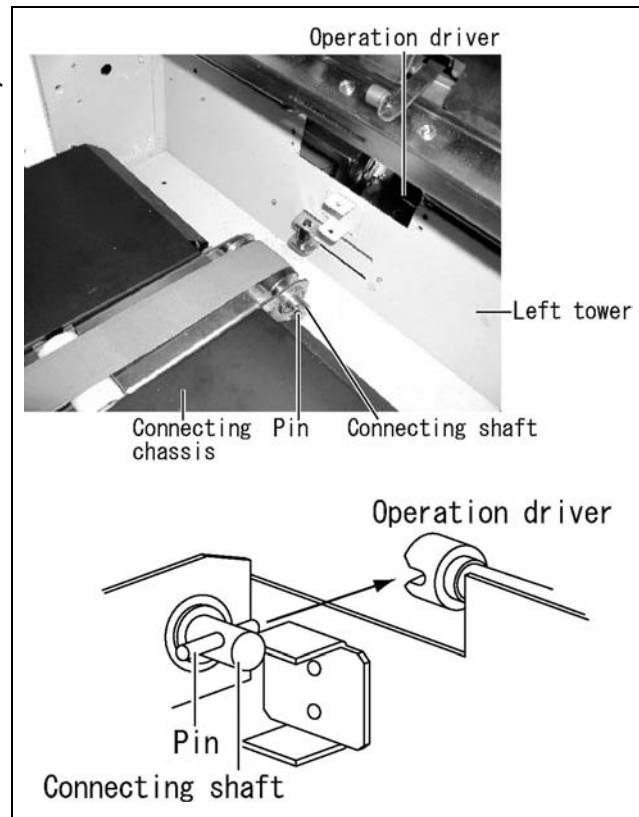

(2) Using Phillips screwdriver, fix the connecting chassis with RKWS4x4 screws (4 locations).

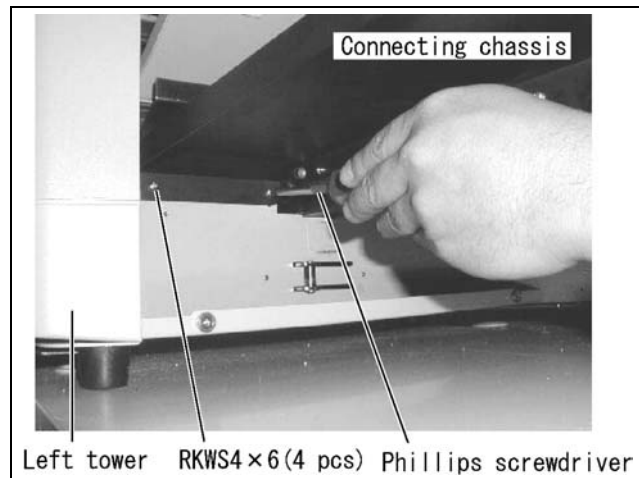

For More Info 
Click Here --->

5. Install the connecting chassis at the right tower.

After moving the collator table to a position where the connecting chassis can be set, hold the connecting chassis in the way as shown on the photo and insert the connecting chassis shaft into the pin (on the left side) of the right tower while pulling the chassis in the direction of arrow with your finger placed inside.

While keeping the state as it is, insert the connecting chassis shaft in the right side pin and remove your fingers placed inside, and then, the chassis is set.

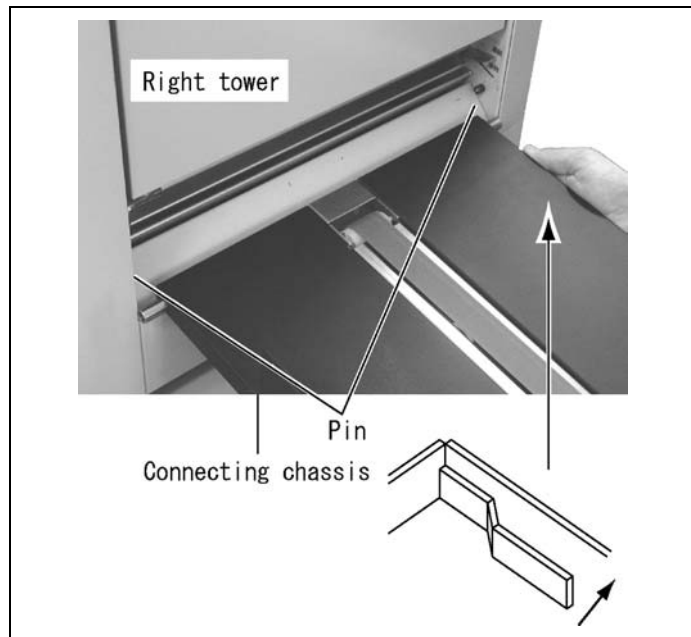

6. Fit the bridge side plate to the connecting chassis with RKWS4x6 screws (2 pcs).

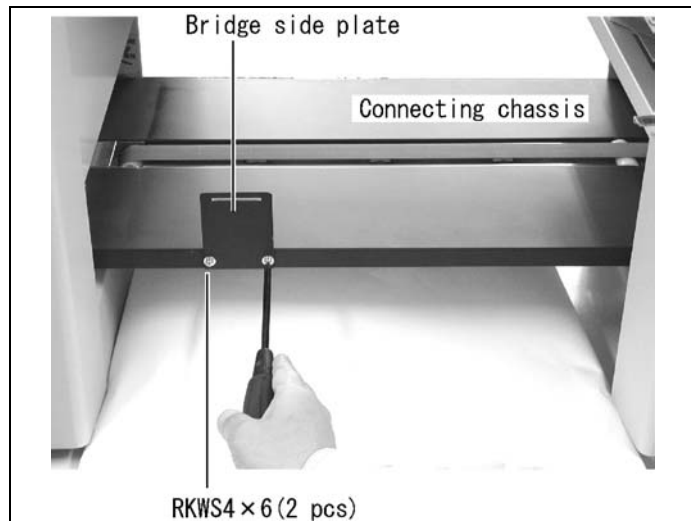

7. Fix the upper chassis

- (1) Insert the left side tip of the upper chassis in the rectangular hole on the fitting plate (L) of the left tower.

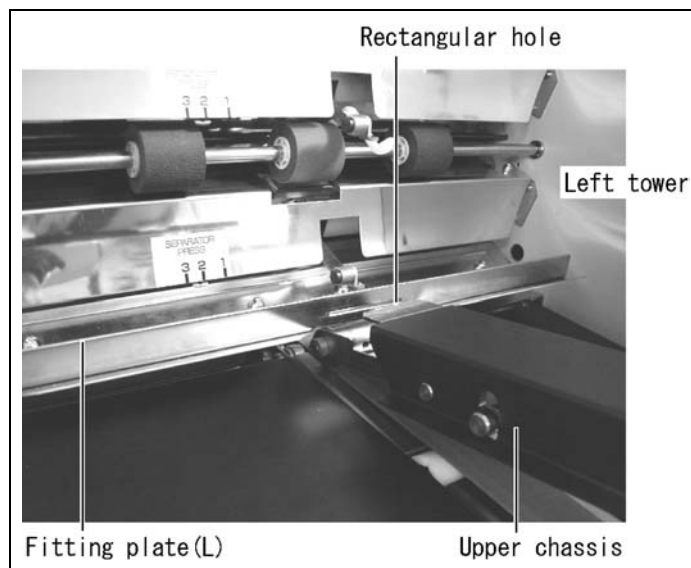

For More Info

Click Here --->



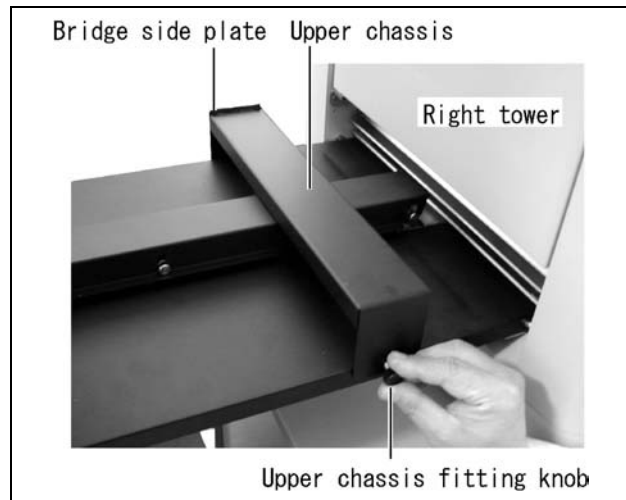

- (2) Insert the right side tip of the upper chassis in the square hole on the bridge side plate, and fit the upper chassis to the connecting chassis using the upper chassis fitting knob.

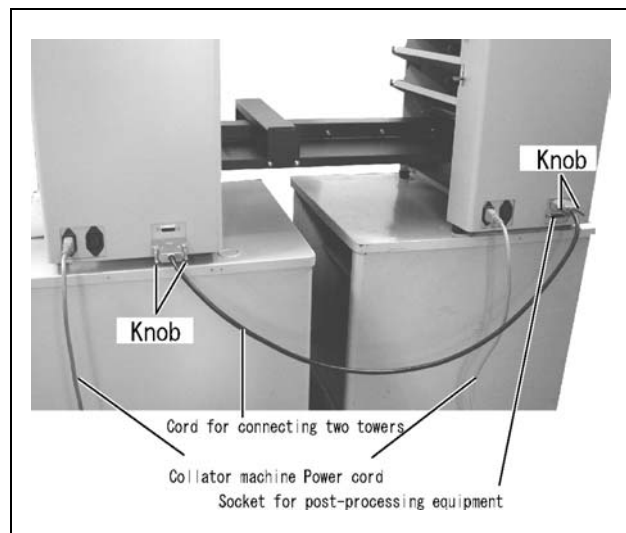

4. HOW TO CONNECT THE CONNECTOR

Insert the power cords of the collators (right and left towers) in the power supply outlet and insert the two collators connecting cord in both tower and fix them firmly.



For More Info  Click Here --->

5. HOW TO OPERATE TWO COLLATORS WHEN THEY ARE CONNECTED

1. As for power supply, first turn on the power switch of the left tower and then turn on the switch of the right tower within five seconds. If the interval between the timings to switch on two collators exceeds five seconds, or the right tower is switched on first, the machines may not work properly.
2. The left tower should be used when key operation on the operation panel is performed.
3. The methods of installation and operation of post-processing equipment vary according to the equipment. Installation and operation should be performed according to the operation manual of respective machine.

<Setting procedures of the system constants>

- * Be sure to set them in order to operate the machine properly.
1. Turn on the power switch of both left and right towers.
 2. Press “O” key on the operation panel of the left tower for three seconds.
[P X] flashes on the counter.
 3. Press the MODE key twice. Then, the counter shows [L X].
 4. (1) In case the left tower and large-capacity stacker are used,
Display of [L . 5] - Press the numerical key “ 7 “ and if [L . 7] is displayed, press the “START/STOP” key.
(2) In case both left and right towers and large-capacity stacker are used,
Display of [L . 5] - Keep this displayed and press the “START/STOP” key.
- * Press the START/STOP” key as the last step. Then, even if the power is turned off, the system constant value is memorized. Re-entry of the data will not be necessary.
 - * Use different L value of the system constant for when both left and right towers and large-capacity stacker are used, from that for when the left tower and large-capacity stacker are used.
 - * If the system constant is not properly set, collating speed will become a little slower when both left and right towers and large-capacity stacker are used.
 - * If the system constant is not properly set, paper jam may occur in the large-capacity stacker when the left tower and large-capacity stacker are used.

Cautions for use!

1. **How to load paper (loading paper when all twenty stations are not used while two collated are connected)**
 - In case 10 or less stations are used, use the left tower only.
(e.g. If paper is loaded on five station of the right tower and on another five stations of the left tower, it may cause paper jam as paper ejected from the left tower meets paper ejected from the right tower.
 - In case eleven to nineteen stations are used, use ten stations of the left tower and use the remainder out of the right tower while loading paper from the bottom station.
2. **REPEAT function cannot be used while two collators are collated.**
3. **INSERT/CHIT functions cannot be used while two collators are connected.**
4. **If the left tower only is used independently, the following three methods can be selected.**
 - Switch on the power of the left tower only.
 - Switch the ejection switching plate to “Independent”
 - When the ejection switching plate on the right tower is set at “Independent”, press the “MODE” key and “6” key on the operation panel of the left tower.

For More Info

Click Here --->



6.RELOCATION OR DISPOSAL

6.1 Relocation

6.1.1 Removal of the machine from its present location

Before removing the machine from its present location, be sure to remove the power plug from the wall outlet.

6.1.2 Transport

- 1) Transport the removed parts, attachments and Operation Manual together with the machine.
- 2) Take care not to expose the collator to strong vibration or shock.

6.1.3 Installation

When installing the collator at its new location, observe the same procedure as when first installing it.

6.2 Disposal

When disposing of the collator, ask a contractor specialized in industrial waste disposal to handle it in accordance to the local regulations.

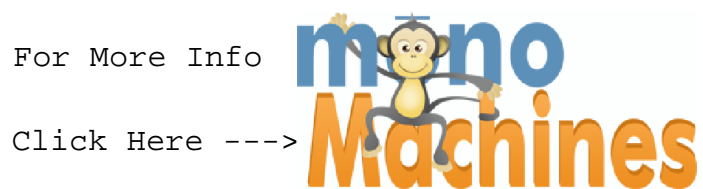

For More Info 
Click Here --->

MBM Corporation