

MARTIN YALE Industries

Model 62001

Model 62002 (230V)

High Speed Letter Opener

Specifications

Functional

SpeedUp to 17,500 per Hour

Maximum Envelope Thickness1/4"

Slitting DepthAdjustable

Load Capacity6"

Physical

Dimensions12-1/4" H x 21-1/4" W x 14 3/4" D (machine only)

Machine Weight34 lbs. (machine only)

Electrical

PowerModel 62001 115 VAC, 1.3 Amp

.....Model 62002 230 VAC

Introduction

Thank you for selecting the Martin Yale Model 62001 High Speed Letter Opener. The Model 62001 is an automatic letter opener capable of processing up to 17,500 mixed envelopes per hour and makes it possible to handle large volumes of different sized envelopes without pre-sorting. Please review this manual in its entirety before attempting to operate your Model 62001. Thorough understanding of this information will help eliminate most operator-associated errors and ensure years of trouble-free performance.

For More Info



Click Here ---->

WARNING: *Keep hands clear of moving belts.*

WARNING: *Never connect power to the opener until you are ready to set up and operate your Model 62001. This machine contains moving parts. During setup, operation, and maintenance keep hands, hair, loose clothing, and jewelry away from all moving parts. Serious bodily injury could result. Service, or disassembly of covers should only be attempted with the power disconnected and locked out.*

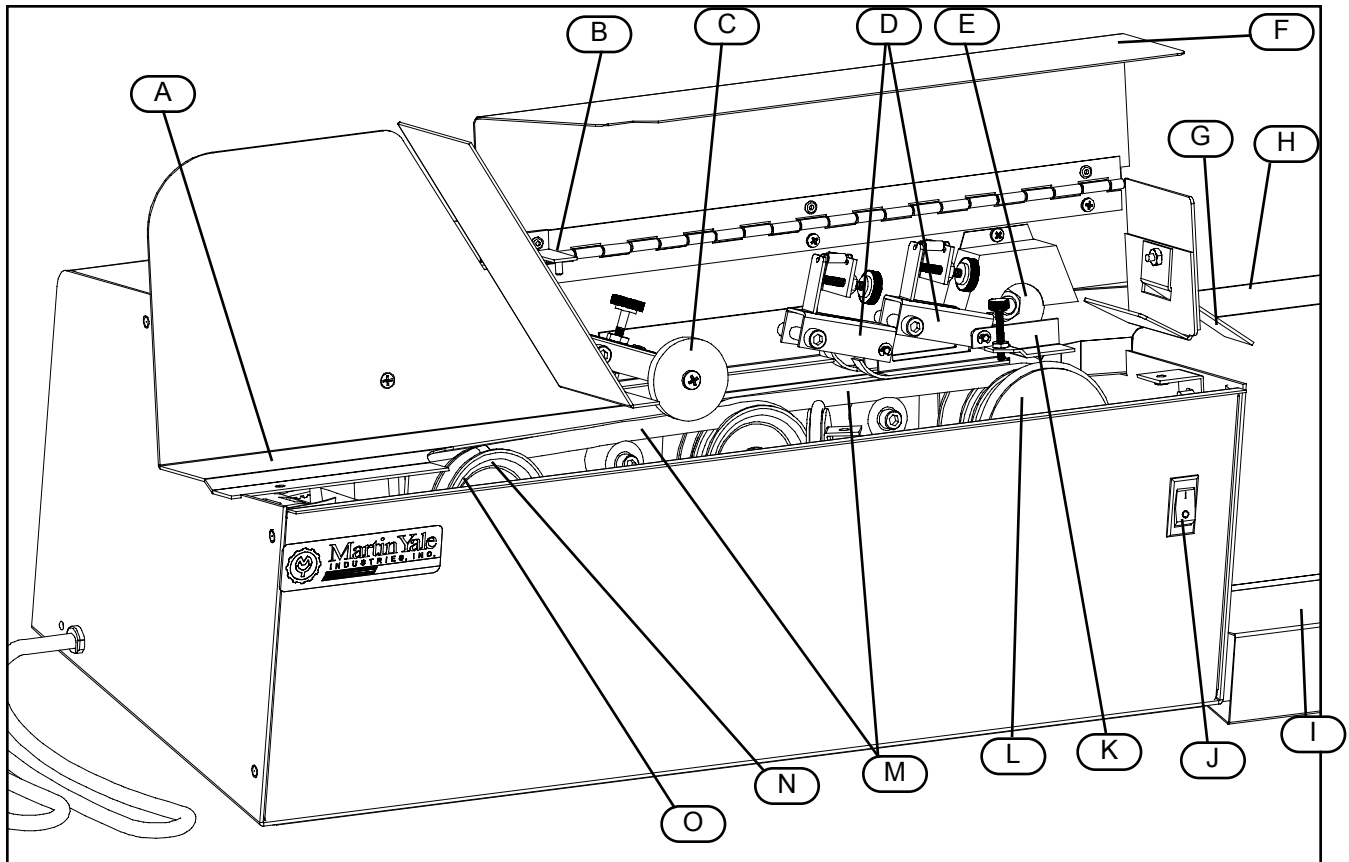

Figure 1

1.0 Parts

- | | |
|-------------------------|------------------------------|
| A. Feed Deck | I. Catcher Base |
| B. Safety Interlock | J. Power Switch |
| C. Holdback Wheel | K. Pressure Plate |
| D. Ski Assembly | L. Ejector Wheel |
| E. Blade Assembly | M. Feed Belt |
| F. Front Cover Assembly | N. Eccentric Pulley Assembly |
| G. Plate Deflector | O. Pulley Flange |
| H. Scrap Bin | |

For More Info

Click Here --->



2.0 Unpacking

Carefully unpack the letter opener. Place all packing materials back in the shipping box and store the box for any future shipment of the letter opener. Inspect the letter opener and all accessories for shipping damage. If any damage is found, contact the carrier immediately.

ATTENTION: For equipment that plugs in, the socket/outlet shall be installed near the equipment and shall be readily accessible.

3.0 Features

The Martin Yale Model 62001 High Speed Letter Opener is a precision-engineered mail handling machine embodying unique design features that make it possible to handle large volumes of different sized envelopes without pre-sorting.

Before operating the Model 62001, please look over the machine to familiarize yourself with these design features and how they function.

3.1 Feed Mechanism

An exclusive feed design mechanism feeds many different size envelopes without pre-sorting and is virtually jam proof.

- * Note the twin spiral feed belts (M, see Fig. 1). Their spiral counterclockwise action shunts envelopes against the back plate for precision slitting. Note that the belt at left is angled more sharply. This “pre-feeds” envelopes to the belt at right.
- * The transporter wheel (not shown), another Model 62001 feature, acts as a further assurance that out-size pieces will be shuttled inward on the front deck (Fig. 2).
- * The holdback wheel (C) prevents jamming at the loading end. Since it is spring loaded, the bulkier the envelope, the greater the pressure exerted by the holdback wheel. This effectively prevents entry of more than one piece of mail at a time.

The combined action of these interrelated parts eliminates many of the problems associated with conventional mail opening machines and explains why the Model 62001 can deliver a high speed capacity of 17,500 mixed envelopes per hour.

3.2 Ski Assembly

The ski assembly (D) guides envelopes straight into the blade assembly (E). Front and back adjustments are factory set to apply correct pressure to letters of varying size. (NOTE: Should adjustment become necessary, loosen the locking nut and adjust the black thumbscrew accordingly. Retighten the locking nut).

3.3 Blade Assembly

Self-sharpening blades made of precision steel (E) cut a measured strip from each envelope, whether fed face-up or face-down. The control knob at right (see Fig. 2) adjusts the blade and permits the operator to vary the width of cut from wide to fine.

3.4 Ejection Assembly

The ejector wheel (L) pulls the envelopes out into the catcher base (I). The pressure plate directly above it (K) keeps the envelope in position for accurate ejection. The plate deflector (G) angles pieces downward into the catcher base.

3.5 Catcher Base

The catcher base (I) receives all opened envelopes as they leave the blade and ejection assemblies. A separate light-weight scrap bin (H) keeps scrap separate from opened envelopes for easier disposal.

3.6 Split Deck

Interiors of most mail opening machines are inaccessible without the removal of the entire operating assembly. The Model 62001 has a unique split deck feature which solves that problem. The deck is split lengthwise into two halves, front (see Fig. 2) and rear. The front half is removable, making cleaning, inspection and repair of the interior of the letter opener easier.

3.7 Eccentric Pulley Assembly

The eccentric pulley assembly has the effect of separating the individual envelopes so that only one envelope is fed at a time. You will note the pulley (N) bounces up and down when the unit is in operation. This is normal.

3.8 Safety Interlock

The tab of the safety interlock (B) is released whenever the front cover assembly (F) is lifted. Power is automatically cut which shuts off the machine so that the operator never comes in contact with moving parts.

3.9 Automatic Resetting Thermal Motor Protection

In the unlikely event of a jam or other machine malfunction, the motor may automatically shut down due to overheating. The thermal breaker will then self reset after the motor cools to normal operating temperature. **Caution: The machine may start running unexpectedly when an overheated motor cools to normal operating temperature.**

3.10 Self-sharpening Blades

The blades are precision ground of high carbon steel. As noted, they adjust for width of cut and are self-sharpening. **Note: Self-sharpening action is continuous whenever mail is not going through the opener and will cause a whirring noise. This is normal.**

4.0 Installation and Set-up

4.1 Installation

Place the Model 62001 on a flat, level surface where it will be used. Make sure ample space is provided for the catcher base. The cooling slots on the machine back should be unobstructed. The socket-outlet shall be installed near the equipment and shall be easily accessible.

4.2 Attach the plate deflector

This is a one-time only installation. Look for the plastic packet inside the shipping carton. It contains the nickel-plated plate deflector and screw. Simply attach outside at point as shown. (See Fig. 2)

4.3 Align the Catcher Base

The catcher base simply sits on the exit side of the folder in a position to catch processed envelopes as they are ejected from the machine (See Fig. 1 for placement). The scrap bin lies in the narrow recess of the catcher base. The entire assembly then is aligned so that the inside front wall of the scrap bin butts against the front edge of the protruding lip of the scrap chute (See Fig. 2).

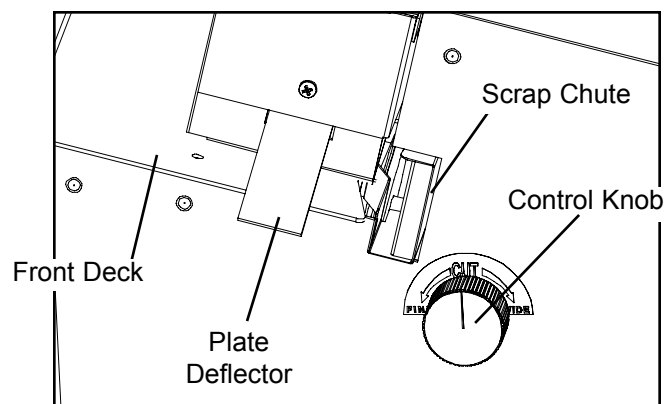

Figure 2

5.0 Operation

5.1 Machine Preparation

Check the control knob (Fig.2) for width of cut desired, from wide to fine. The cut should be deep enough to open envelopes cleanly but fine enough to insure that the blade does not come into contact with contents such as checks and money orders, etc., nor coins, staples and paper clips. Make sure the Model 62001 is 'OFF' as indicated by the 'O' on the power switch. Plug the machine into an appropriate power outlet.

5.2 Mail Preparation

Using a table or other flat surface, hand jog (tamp while holding the mail loosely) a handful of mail (not more than a 3" high stack) so contents move to the bottom of the envelopes. Lightly fan stack to insure that envelopes are separated. **NOTE: Some types of envelopes may open easier on the bottom edge rather than the top. In that case, jog the envelopes so that the contents move to the top.** Smooth all curled edges or torn flaps so the edge entering the Model 62001 is free of protruding surfaces that could snag on machine parts. Remove and hand process any severely damaged letters.

5.3 Mail Processing

- 1) Load prepared envelopes on the feed deck (A) at the left side of the machine with the edge to be cut inward.
- 2) Turn the machine 'ON' by depressing the power switch at right (J). The Model 62001 will now feed and slit the loaded envelopes.
- 3) The opened envelopes should now start processing and stacking in the catcher base. Do not let the envelopes accumulate higher than 4 inches, as this may cause a back jam.
- 4) Remove chads regularly by lifting out the scrap bin (H) and emptying.

6.0 Routine Maintenance

6.1 Housekeeping

Keep the Model 62001 clean. Smooth functioning of the Model 62001 requires daily removal of accumulated scrap with a soft bristled brush. If scraps are stuck between blades, remove these also. Be sure to check machine before each use for signs of such accumulation. Periodically remove the front deck for inspection of interior.

6.1.1 Front Deck Removal

Before attempting to remove the front deck, make sure the letter opener is turned 'OFF' and the machine is unplugged. Unscrew the two Phillips head screws, one on the left and one on the right, and lift out the front deck. **Caution: Do NOT remove the screw in the center (near transporter wheel).** To reinstall, angle the front deck in and downward. Then, while lifting the ski assembly (D), slide the front deck into position. Reinsert screws and tighten.



6.2 Feed belts

Approximately once for every twenty hours of machine operation, clean the feed belts of the unit with soap and water. Turn the machine off and on repeatedly to make sure that the entire lengths of the belts are cleaned.

6.3 Holdback wheel maintenance

The holdback wheel does not rotate; hence it will wear a flat spot over time. If this occurs, simply loosen the center screw of the holdback wheel and rotate it to expose a fresh surface.

6.4 Blade Maintenance

For each 40,000 pieces of mail processed, coat both the upper and lower blades with a blade emollient such as Premier Brand Trim Ease Lubricant (Martin Yale #MRS037046, available through your Martin Yale Dealer).

7.0 Troubleshooting

Several of the most commonly encountered problems are listed below along with the most common causes and remedies.

Problem	Possible Cause	Remedy
7.1 Envelopes Jam	Scrap build-up in ski assembly and blade assembly area	Clean as outlined in section 6.1
	Scrap bin filled beyond capacity	Clear scrap out of letter opener and make sure the scrap bin is cleared regularly during machine use
7.2 Feeding Problems	Feed belts dirty	Clean as described in section 6.2
	Holdback wheel worn	Turn holdback wheel as described in section 6.3
	Envelope too thick	Make sure letter thickness is no more than 1/4"
7.3 Envelopes Only Partially Cut	Transport Wheel not rotating	Verify that transport wheel spins as the opener runs
	Ski Assembly misadjusted	Make sure ski assembly moves freely, and the springs are still attached to both ends of it.
7.4 Envelope Contents Cut	Cut adjusted to wide	Set the cut width adjustment to a narrower setting
	Envelopes not tamped	Prepare mail as outlined in section 5.2

Problem	Possible Cause	Remedy
7.5 Not Cutting or Abnormal Noise	Blades worn or lubrication needed	Lubricate blades or replace
7.6 Will Not Run	Paper jam	Unplug opener and clear jam
	Lid not closed	Make sure front cover assembly is closed
	Power disconnected	Try the opener in a known good outlet
	Thermal breaker tripped	Let the Model 62001 cool for at least 1/2 hour, then try again
	Fuse blown (non-resettable)	Replace fuse
7.7 Motor Runs, Belt Not Rotating	Electrical malfunction	Call Martin Yale customer service
	Timing belt disconnected from motor or belt broken	Connect or replace belt

For More Info

Click Here --->



PART LIST			
REF.	PART No.	DESCRIPTION	QTY.
A	M-S037020	18/3 SV CORD	1
B	M-S033067	1632 MICRO SWITCH	1
C	M-S033053	SPST ROCKER SWITCH	1
D	M-S045225	15MFD MOTOR CAP	1
E	M-S045231	FUSE HOLDER	1
F	M-S63601106	5A FUSE	1
G	M-S021064	110V MOTOR 1501X AC	1

EUROPEAN			
REF.	PART No.	DESCRIPTION	QTY.
A	M-S037286	EUROPEAN CORD SET.	1
D	M-S045249	6MF MOTOR CAP	1
G	M-S021065	CV7 AC MOTOR 220V	1

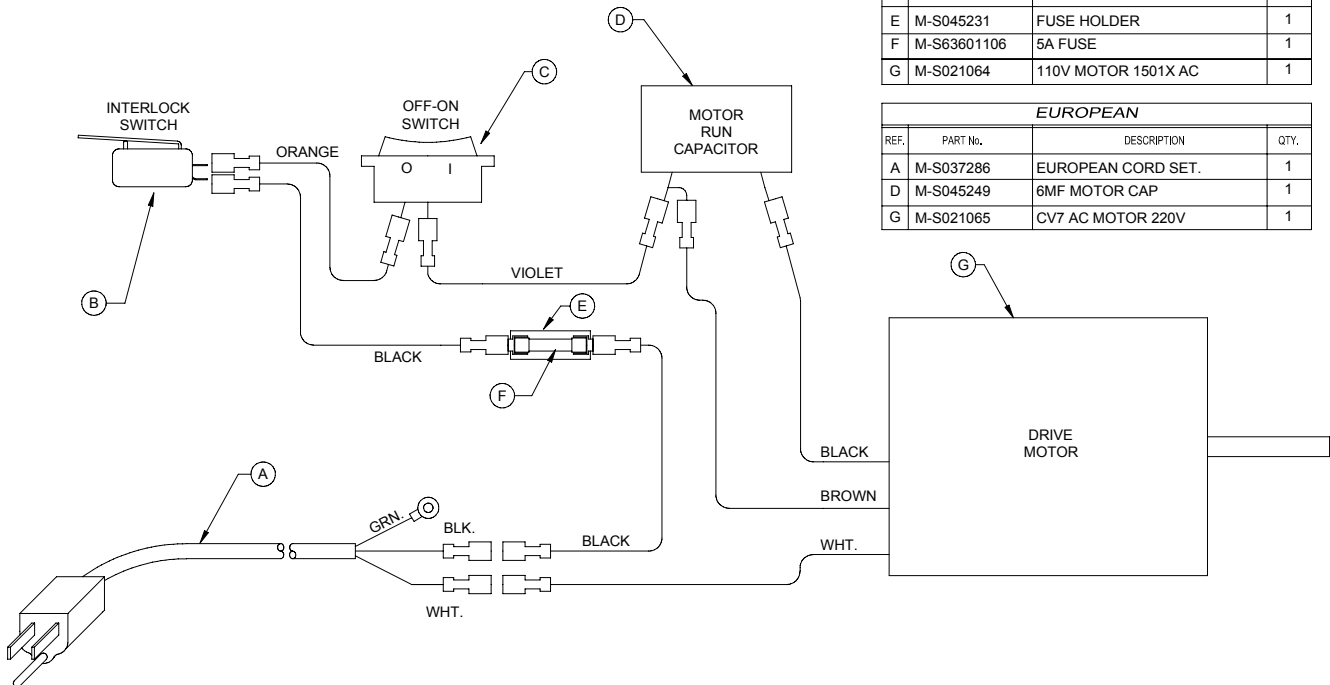

Wiring Diagram Model 62001 (115 VAC) / 62002 (230 VAC) Letter Opener

For More Info 
Click Here --->



251 Wedcor Avenue • Wabash, IN 46992
Phone: 260/563-0641 • FAX: 260/563-4575
website: www.martinyale.com • email: info@martinyale.com

MADE IN U.S.A.