



450 SERIES HOPPER SHREDDERS

**20452
20453**

Dahle North America, Inc.

375 Jaffrey Road
Peterborough, NH 03458
Tel: (603) 924-0003 • Fax: (603) 924-1616
Email: shredders@dahle.com
w w w . d a h l e . c o m

OPERATION MANUAL

20451.90.1830 – 01/04 -

Congratulations on your purchase of a DAHLE Hopper Feed Shredder! We here at DAHLE USA are dedicated to providing rugged and dependable products for the large, and not so large office. We are sure your new DAHLE Hopper Feed Shredder will meet or exceed your expectations of quality and service.

If you have any questions regarding your new DAHLE paper shredder, call your sales representative, or call DAHLE Customer Service, toll free at (800) 995-1379 between 8:30 am and 5:00 pm Monday through Friday, EST.

Check off the model and record the serial number for your records in the space provided below.

- 20452 20453

Serial Number: _____

DIAGRAM KEY

1. Key Lock / Safety Stop Button
2. Reset Button
3. Power Lamp
4. Forward Button
5. Stop Button
6. Reverse Button
7. Leveling Foot Lock Nut
8. Leveling Foot
9. Waste Door
10. Waste Bin
11. Shred Bag
12. EDP Shelf
13. Access Door
14. Main Plug

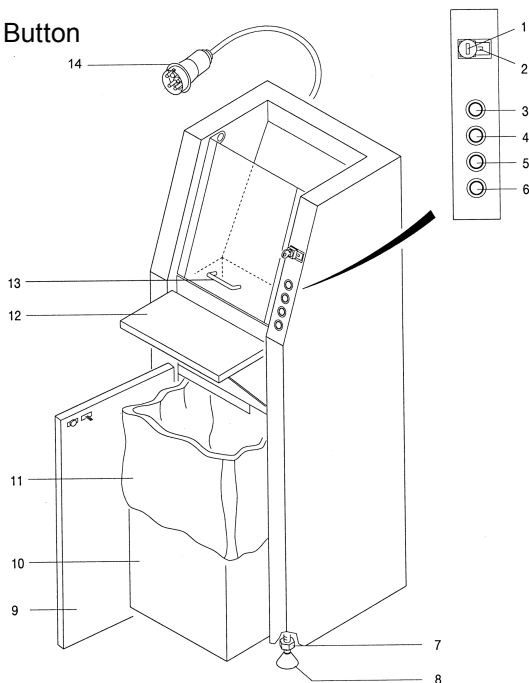

704

DAHLE SHREDDER SUPPLIES AND ACCESSORIES

Shred Bags (100 per box)

Item No.	Models
701	Personal & 20300 Series 20400, 20500 & 20600 Series
705	20800 Series
706	High Capacity Models

740G

Shredder Oil (All Models)

740	Box of 4 16oz. Bottles Box of 4 1gal Bottles
-----	---

Automatic Oiling System

SAO-120	4 Liter Auto Oiler
---------	--------------------

CARING FOR YOUR SHREDDER

Clean covers with a clean dry cloth. Do not use water or solvents. Make sure you disconnect your shredder from its power source before cleaning.

Paper shredders, like all mechanical equipment, need proper maintenance to ensure efficient operation. Periodic lubrication of the cutting blades is important to offset the friction generated within the cutting head. Frequency of lubrication will vary depending on the shred size and the amount of usage. A strip-cut shredder receiving light use (1 – 2 hours per week) will require lubrication only once or twice a month, while the same machine used 1 – 2 hours per day will require lubrication weekly. A cross-cut shredder should be lubricated every ½ hour of shredding time to maintain maximum capacity and efficiency.

The procedure for lubricating your shredder is simple, and can be performed by any operator. The oil is packaged in a squeeze bottle and is applied directly to the cutting blades through the feed opening (3). Run a fine stream of lubricant from one side of the feed opening to the other. Run the shredder in REVERSE for a few seconds to help distribute the lubricant evenly. You can now continue shredding as usual.

DAHLE Shredder Oil is the only lubricant you should use in your paper shredder. It has been specially formulated so as not to leave any residue that could attract dust and clog the shredding mechanism. You can order DAHLE Shredder Oil (item # 740) from your local dealer.

Repairs on your paper shredder should only be performed by qualified technicians. **If you need service**, contact your local dealer, or you can contact DAHLE USA Customer Service between 8:30 am and 5:00 pm EST at (800) 995-1379.

BEFORE YOU CALL FOR SERVICE

SYMPTOM	POSSIBLE CAUSES	SOLUTION
No Power	<ul style="list-style-type: none"> ❶ Unit not unlocked ❷ Unit unplugged ❸ Outlet dead ❹ Door not fully closed ❺ Shred Bag full 	Unlock Safety Button and press reset Connect to outlet Reset circuit breaker Close Door Change Shred Bag
Low capacity	<ul style="list-style-type: none"> ❶ Cutting blades dry 	Lubricate cutting blades according to instruction.

IF ANY OTHER PROBLEMS OCCUR, CALL YOUR AUTHORIZED DAHLE SERVICE DEALER

BEFORE YOU SHRED

- Read all instructions carefully.
- Record the Model and Serial Number in the space provided inside the front cover of the booklet.
- Roll shredder into position
- Unscrew leveling feet (8) until shredder is level and stable.
- Lock Leveling Feet with Lock Nuts (7).
- Be sure the electrical outlet provides the proper power for your shredder (see rating label on rear of shredder).
- Install Shred Bag (see: “CHANGING THE SHRED BAG”).

CAUTION: KEEP LOOSE GARMENTS, HAIR, JEWELRY, ETC. AWAY FROM FEED OPENING.



WARNING: DO NOT LET CHILDREN OPERATE THIS, OR ANY OTHER OFFICE EQUIPMENT



TURNING ON YOUR SHREDDER

- ❶ Turn key clockwise to unlock Red Safety Button (1).
- ❷ Press Reset Button (2).
- ❸ Green Power Lamp (3) should light.
- ❹ Shredder is now in the Stand-by mode.
- ❺ Press Red Safety Button to Turn Shredder Off.

ALWAYS TURN SHREDDER OFF IF IT WILL BE UNATTENDED FOR LONG PERIODS OF TIME

SHREDDING

Turn shredder on. Press Forward Button (4) to begin shredding operation.

The shredder can be fed either from the top or the front. For this purpose, a feed opening is provided on the top for emptying waste paper baskets (paper only) and at the front for feeding cut stock and continuous forms.

Three (3) EDP shelves can be folded up to facilitate the shredding of continuous forms.

The shredder will not operate unless the Waste Door (9) and Access Door (13) are completely closed.

Microfiche and transparencies can also be shredded in the same manner as paper, however, you should shred a piece of paper after every 8 or 10 sheets of plastic. This helps clean plastic particles out of the shredding mechanism.

CAPACITY

Capacity is the number of sheets of 8½" x 11" paper that can be shredded at one time. These figures are approximate and machines may vary slightly due to various conditions. It is not recommended that you try to run your shredder at maximum capacity, as this increases the chance of a paper jam.

<u>Model</u>	<u>20 Lb. Bond</u>	<u>16 Lb. Bond</u>
20452	85	100
20453	65	85

CLEARING A PAPER JAM

If too many sheets of paper are fed into your shredder at one time, it may cause a paper jam. Running your shredder at maximum capacity increases the chance of a paper jam. If a paper jam occurs, it is easy to clear by following these simple steps:

- ① Turn shredder off by pressing the Stop Button (5).
- ② Press the Reverse Button (6) to clear jam.
- ③ Open Access Door (13) to remove jammed paper.
- ④ After paper has been removed from the Hopper, close Access Door(13).
- ⑤ Separate some of the sheets and continue shredding.

CHANGING THE SHRED BAG

When the Shred Bag (11) is full, the shredder will automatically shut down. Changing the Shred Bag is quick and easy if you follow these simple directions.

- ① Turn shredder off
- ② Open Waste Door (9) to expose waste Bin (10) and Shred Bag (11).
- ③ Roll Waste Bin and full Shred Bag from shredder.
- ④ Dispose of full Shred Bag.
- ⑤ Install new Shred Bag in Waste Bin, draping end of Shred Bag over edge of Waste Bin.
- ⑥ Roll Waste Bin, with new Shred Bag installed, back into shredder.
- ⑦ Close Waste Door.
- ⑧ Turn on shredder and continue shredding.

NOTE: SHREDDER WILL NOT OPERATE UNLESS DOOR IS COMPLETELY CLOSED