



**20400 SERIES
INTERMEDIATE OFFICE SHREDDERS**

**20404
20414
20422
20430
20434**

**20500 SERIES
ECONOMY OFFICE SHREDDERS**

**20506
20514**

Dahle North America, Inc.
375 Jaffrey Road
Peterborough, NH 03458
Tel: (603) 924-0003 • Fax: (603) 924-1616
Email: shredders@dahle.com
w w w . d a h l e . c o m

OPERATION MANUAL

20404.90.0830 – 03/04 –

Congratulations on your purchase of a DAHLE 400 / 500 Series Office Shredder! We here at DAHLE North America are dedicated to providing rugged and dependable products for the large, and not so large office. We are sure your new DAHLE 400 / 500 Series Office Shredder will meet or exceed your expectations of quality and service.

If you have any questions regarding your new DAHLE paper shredder, call your sales representative, or call DAHLE N.A. Customer Service, toll free, at (800) 995-1379 between 8:30 am and 5:00 pm Monday through Friday, EST.

Check off the model and record the serial number for your records in the space provided below.

- 20404 20414 20422 20430 20434 20506 20514

Serial Number: _____

DIAGRAM KEY

1. Feed Opening
2. Light Barrier
3. On/Off/Reverse
4. Warning LED indicator (Bag full, Door ajar)
5. Power Light
6. Transport Bolts
7. Waste Bin
8. Shred Bag
9. Door Pull
10. Door

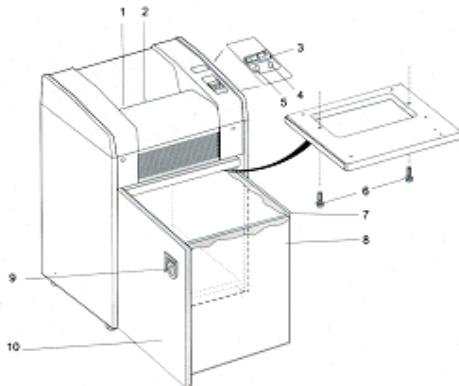

READ ALL INSTRUCTIONS BEFORE OPERATING YOUR SHREDDER

BEFORE YOU CALL FOR SERVICE

SYMPTOM	POSSIBLE CAUSES	SOLUTION
No Power	<ul style="list-style-type: none"> ❶ ON/OFF Switch set to wrong position ❷ Unit unplugged ❸ Outlet dead ❹ Door not fully closed ❺ Shred Bag full 	<ul style="list-style-type: none"> Move Switch to "I" (on) position. Connect to outlet Reset circuit breaker Close Door Change Shred Bag
Low capacity 704	<ul style="list-style-type: none"> ❶ Cutting blades dry 	<ul style="list-style-type: none"> Lubricate cutting blades according to instruction.

DAHLE SHREDDER SUPPLIES AND ACCESSORIES

Shred Bags (100 per box)

405

Item No.	Models
701	Personal & 20300 Series
705	20400, 20500 & 20600 Series
706	20800 Series
	High Capacity Models

Waste Bin

605	20400 Series
	20500 Series

Shredder Oil (All Models)

740	Box of 4 16oz. Bottles
740G	Box of 4 1gal Bottles
740G/1	1 gallon bottle

Automatic Oiling System

SAO-120	4 Liter Auto Oiler
---------	--------------------

READ ALL INSTRUCTIONS BEFORE OPERATING YOUR SHREDDER

CHANGING THE SHRED BAG

When the Shred Bag (8) is full, the shredder will automatically shut down. The electronics will cause the amber Warning LED Indicator to light. Changing the Shred Bag is quick and easy if you follow these simple directions.

- ① Turn shredder off
- ② Open Door (10) using Door Pull (9) to expose Waste Bin (7) and Shred Bag (8).
- ③ Pull the Waste Bin and full Shred Bag out of the shredder.
- ④ Dispose of full Shred Bag.
- ⑤ Install new Shred Bag in Waste Bin, draping end of Shred Bag over edge of Waste Bin.
- ⑥ Push Waste Bin, with new Shred Bag installed, back into shredder.
- ⑦ Close Door.
- ⑧ Turn on shredder and continue shredding.

CARING FOR YOUR SHREDDER

Clean covers with a clean dry cloth. Do not use water or solvents. Make sure you disconnect your shredder from its power source before cleaning.

Paper shredders, like all mechanical equipment, need proper maintenance to ensure efficient operation. Periodic lubrication of the cutting blades is important to offset the friction generated within the cutting head. Frequency of lubrication will vary depending on the shred size and the amount of usage. A strip-cut shredder receiving light use (*1 – 2 hours per week*) will require lubrication only once or twice a month, while the same machine used 1 – 2 hours per day will require lubrication weekly. A cross-cut shredder should be lubricated every ½ hour of shredding time to maintain maximum capacity and efficiency.

The procedure for lubricating your shredder is simple, and can be performed by any operator. The oil is packaged in a squeeze bottle and is applied directly to the cutting blades through the feed opening (3). Run a fine stream of lubricant from one side of the feed opening to the other. Run the shredder in REVERSE for a few seconds to help distribute the lubricant evenly. You can now continue shredding as usual.

DAHLE Shredder Oil is the only lubricant you should use in your paper shredder. It has been specially formulated so as not to leave any residue that could attract dust and clog the shredding mechanism. You can order DAHLE Shredder Oil (item # 740) from your local dealer.

Repairs on your paper shredder should only be performed by qualified technicians. **If you need service**, contact your local dealer, or you can contact DAHLE North America Customer Service between 8:30 am and 5:00 pm EST at (800) 995-1379.

NOTE: SHREDDER WILL NOT OPERATE UNLESS DOOR IS COMPLETELY CLOSED

SAFETY INSTRUCTIONS



- Read the operating instructions carefully before operating your shredder!
- Do not use in the vicinity of flammable liquids or gases.
- Do not use in the vicinity of corrosive materials.
- Do not expose to water or wet conditions.
- Do not let children operate this, or any other, office equipment.
- Do not reach into the cutting mechanism during operation – not even from the top or with objects.
- Do not operate the shredder for a period of more than 5 minutes in no-load operation (operation without paper).
- Keep hair clear of machine.
- Keep neckties clear of machine.
- Keep bracelets, or any other jewelry, clear of machine.
- Power connection must be accessible at all times.
- Disconnect from power supply before servicing.
- The safety devices must not be disabled or removed.



ON / OFF TIME: 20434: 10 MIN ON / 20 MIN OFF
 20506: 5 MIN ON / 20 MIN OFF
 20514: 5 MIN ON / 20 MIN OFF

BEFORE YOU SHRED

Remove Transport Bolts (6) with wrench provided.

- Read all instructions carefully.
- Record the Model and Serial Number in the space provided inside the front cover.
- Be sure the electrical outlet provides the proper power for your shredder (see rating label on rear of shredder).
- Install Shred Bag (see: “CHANGING THE SHRED BAG”).

ALWAYS TURN SHREDDER OFF IF IT WILL BE UNATTENDED FOR LONG PERIODS OF TIME

TURNING ON YOUR SHREDDER

- ① ON, OFF and REVERSE are controlled by the black Rocker Switch (3) on the top of the shredder.
- ② Moving the switch to the "I" (ON) position places the shredder in the standby mode.
Note: Shredder will run momentarily.
- ③ Moving the switch to the center or "O" (OFF) position turns the shredder off.
- ④ The REVERSE position "R" will be discussed in "CLEARING A PAPER JAM".

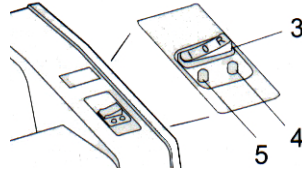

SHREDDING

Turn shredder on. Insert paper squarely into Feed Opening (1). A light barrier (2) will automatically activate the shredding mechanism. Continue feeding paper into the Feed Opening until the shredding mechanism begins to draw the paper in. At this point, allow the paper to feed into the shredder on its own. Once the paper has passed completely through the shredding mechanism, the electronic controls will automatically stop the machine.

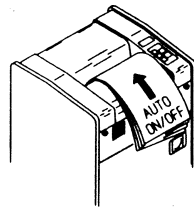

Microfiche and transparencies can also be shredded in the same manner as paper, however, you should shred a piece of paper after every 8 or 10 sheets of plastic. This helps clean plastic particles out of the shredding mechanism.

CAPACITY

Capacity is the number of sheets of 8½" x 11" paper that can be shredded at one time. These figures are approximate and machines may vary slightly due to various conditions. It is not recommended that you try to run your shredder at maximum capacity, as this increases the chance of a paper jam.

<u>Model</u>	<u>20 Lb. Bond</u>	<u>16 Lb. Bond</u>
20404	16	
20414	12	15
20422	10	12
20430	5	6
20434	4	6
20506	25	30
20514	12	15

CLEARING A PAPER JAM

If too many sheets of paper are fed into your shredder at one time, it may cause a paper jam. Running your shredder at maximum capacity increases the chance of a paper jam. If a paper jam occurs, it is easy to clear by following these simple steps:

- ① Turn shredder off using ON/OFF/REVERSE switch (3)
- ② Firmly pull on paper sticking out of Feed Opening while holding ON/OFF/REVERSE switch in the REVERSE (R) position.
- ③ After paper has been removed from the Feed Opening, move the ON/OFF/REVERSE switch back to the ON (I) position.
- ④ Separate some of the sheets and continue shredding.

ALWAYS TURN SHREDDER OFF IF IT WILL BE UNATTENDED FOR LONG PERIODS OF TIME

IT IS NOT RECOMMENDED RUNNING SHREDDERS AT MAXIMUM CAPACITY